

Teacher Guide 2

This set of guides has been prepared for steeluniversity.org 'ambassadors' and approved teachers and trainers to help in using the website resources in a range of teaching and learning scenarios.

They are not intended for general release to the public and on no account should electronic versions be posted on publicly-accessible websites or file servers.

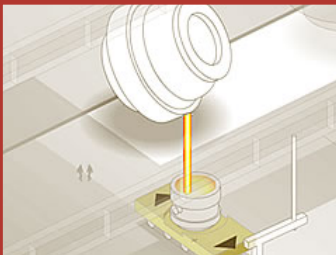

1. Basic Solutions for All Four Grades in EAF and Secondary Steelmaking Simulations

These are suggested production routes that Teachers/Demonstrators can use. They should lead to a successful result (at University Student level), although this will not be the best (least cost) solution.

2. Production Solutions for the Linepipe Steel Grade in BOF, EAF, Secondary Steelmaking and Continuous Casting Simulations

These are suggested production routes for a single grade through several different steelmaking simulations which are, or will soon be, linked. Note: Suggested additions for secondary steelmaking will need to be re-calculated if the simulations are linked (using a saved cast from EAF/BOF) rather than run as 'standalone'.

3. Suggestions for Using Steelmaking Simulations with Adults and Children

Case studies and materials (recipes, equipment requirements, certificates etc.) for running simulations and/or steelmaking challenges with different age groups.

If you have any feedback regarding this guide, please get in touch via the [contact page](#) at www.steeluniversity.org.

Production Solutions for the Linepipe Steel Grade in Basic Oxygen Furnace, Electric Arc Furnace, Secondary Steelmaking and Continuous Casting Simulations



1	Purpose of this Guide	1
2	Format of Suggested Routes	1
3	Basic Oxygen Steelmaking Simulation	2
4	Electric Arc Furnace Simulation	3
5	Secondary Steelmaking Simulation	4
6	Continuous Casting Simulation	5

1 Purpose of this Guide

This guide is designed to give demonstrators suggested production solutions to complete the Basic Oxygen Furnace (BOF), Electric Arc Furnace (EAF), Secondary Steelmaking (SSM) and Continuous Casting (CC) simulations for a linepipe grade steel. This includes reference to the Registration and Log-in facilities, which allow saved data to be retrieved and used in subsequent simulations. It does not cover suggestions for any customized alloy compositions that may be added to the simulation manually, nor does it include any explanation as to why reactions occur or why certain additions are made. Reference should be made to the relevant module and user guide, which are available at www.steeluniversity.org.

It should be noted that suggested additions for SSM are only appropriate when the simulations are run as 'standalone'. If retrieved data is loaded (i.e. the simulations are linked), the user will be required to re-calculate any additions based on the composition of the loaded cast to achieve a successful result.

2 Format of Suggested Routes

Each suggested route details the typical temperatures, slag and alloy additions, flow rates etc. in a series of steps that end in the steel being tapped into the final vessel or cast into its final form.

These are not the only possible production routes and will not give the best (lowest cost/tonne) result. The exact additions or process conditions will depend on the specific starting composition that the simulation presents each time it is started. However, the amounts and times suggested in this guide have been adjusted so that most heats will meet the necessary criteria for a successful result.

3 Basic Oxygen Steelmaking Simulation

- Choose user level University Student and go to next screen.
- Select steel grade Linepipe Steel and go to next screen.
- Select the following additions: 260 tonnes Hot metal; 11000 kg Light Scrap; 7000 kg Heavy Scrap; 9000 kg Iron Ore; 4800 kg Lime; 7900 kg Dolomite. Go to next screen.

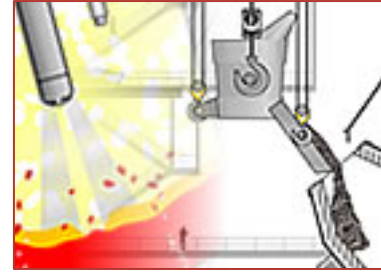

- Watch loading sequence, takes about 30 seconds. The simulation then becomes active and the simulation rate can be adjusted.
- Lower lance until it is approximately level with the black tapping arrow on the right hand side of the furnace.

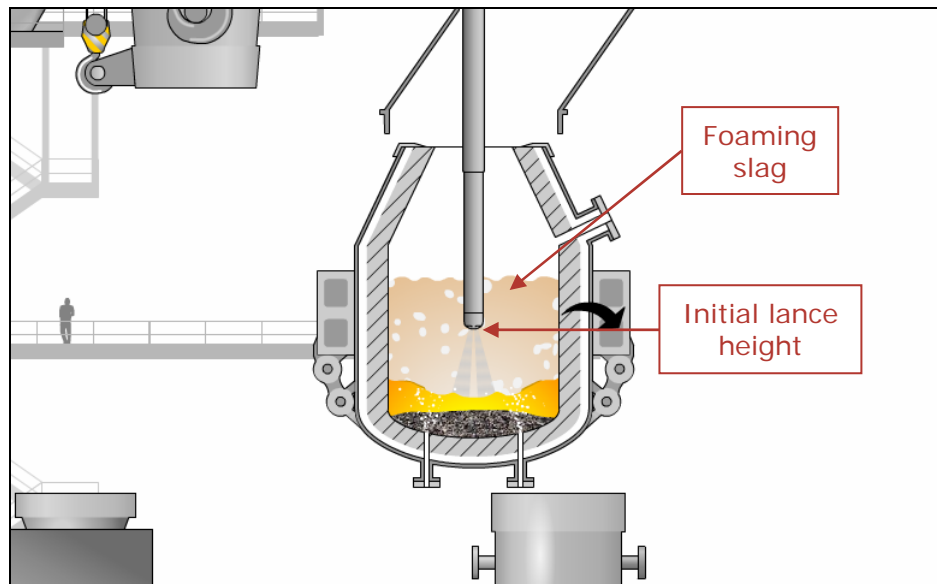

- Increase the oxygen flow to 3.0 Nm³/min. A foaming slag is created.
- When the foaming slag fills half the furnace, carefully adjust the lance height downwards until the slag level remains constant.
- Press P at any time to view the melting path on the Fe-C phase diagram. This shows the carbon content and temperature of the molten steel as a function of time. Close the box to continue.
- Monitor carefully the oxygen flow rate and the required temperature range. The blow should be complete after 14500 Nm³ O₂. Turn off the oxygen flow and make a substance measurement by pressing 'R' and then 'Take new sample'. A liquid steel composition is displayed a few minutes later. Close box to continue.
- Remove the lance and then tap using the curved arrow on the right-hand side of the vessel.
- Note that the final sulfur level is above specification and will need to be removed in subsequent secondary steelmaking operations.

4 Electric Arc Furnace Simulation

- Choose user level University Student and go to next screen.
- Select steel grade Linepipe Steel and go to next screen.
- Select the following scrap: 45 t No1 Bundles, 45 t No2 Bundles and go to next screen.
- Distribute the scrap into 3 baskets and go to next screen.
- Pick up the first scrap basket (leftmost) and charge the furnace with basket no. 1.
- Lower electrodes until they stop and then turn on the electricity by changing tap setting to '4'.
- Melt the scrap completely.
- Charge the furnace with basket no. 2 and melt completely.
- After completely melting the second basket, charge the third basket into furnace.
- Make the following additions before completely melting the second basket: 1000 kg lime and 1000 kg dolomite.
- Don't do any alloying additions at this stage, they should be made during secondary steelmaking.
- Carefully watch the temperature after melting and heat the molten steel to about 1690 °C.
- Start tapping when the temperature comes into the tapping temperature region (1655-1685 °C).

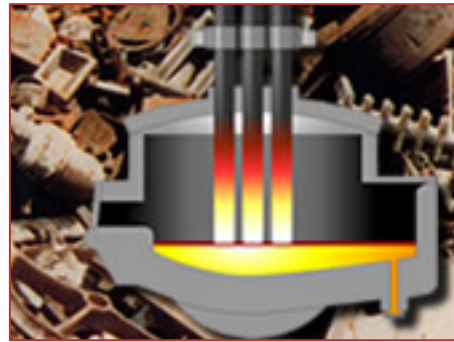

5 Secondary Steelmaking Simulation

- Choose to run simulation as "Standalone". You can choose to "Load data..." but you will have to re-calculate all additions.
- Choose user level University Student and go to next screen.
- Select steel grade Linepipe Steel and go to next screen.
- Start simulation.
- Select "maximum" CaO slag composition (45% CaO).
- Select 2800 kg synthetic slag.
- Start tapping the furnace.
- Add 300 kg Aluminum pebbles IMMEDIATELY.
- After tapping is complete, move the ladle car out 2 stops.
- Pick up the ladle with the crane and transport to the ladle furnace.
- Do not use any power or stirring.
- Make the following additions: 50 kg Recarburiser, 5000 kg Ferro-Manganese High Purity, 610 kg Ferro-Silicon 75, 60 kg Ferro-Niobium and 100 kg Calcium-Silicon Powder.
- Heat on full power to 1625 °C.
- Raise the ladle furnace lid.
- Transport the ladle car back towards the tank degasser.
- Cover the tank and select the maximum vacuum and argon flow rate.
- Degas for 30 minutes.
- Uncover the tank.
- Watch the time and temperature and consider whether the temperature will be sufficient for casting. Otherwise transport the ladle to the ladle furnace and heat on full power until sufficient temperature is achieved.
- Transport the ladle to the slab caster.
- At the required time the temperature should be with the required range.
- Drop the ladle onto the slab caster using the crane.

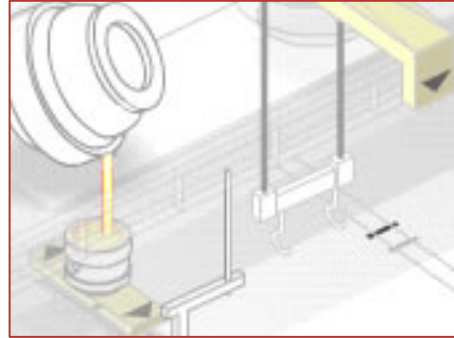

6 Continuous Casting Simulation

- Proceed through the first two screens and select University Student user level. Go to next screen.
- Select Linepipe Steel grade and go to next screen.
- Choose a casting speed of 1.2 m min^{-1} and a cooling rate of $0.6 \text{ kg water per kg steel}$.
- On the next screen, select Mold Powder C.
- Next, select a medium Soft Reduction setting.
- Move on to the ladle arrival ordering screen. Select a temperature of $1570 \text{ }^\circ\text{C}$ for ladle 1. **Note: Use the arrow buttons on the controls. If you type values directly into their boxes, you must press the Enter key.** For ladle 2, select an arrival time of 40 minutes and a temperature of $1560 \text{ }^\circ\text{C}$. For ladle 3, select an arrival time of 80 minutes and a temperature of $1560 \text{ }^\circ\text{C}$.
- Move on to selection review screen. Stop at the review screen and go through each choice to make sure these are correct. Press 'next' to start simulation.
- Start the process by increasing the flow from the ladle to $10\,000 \text{ kg min}^{-1}$.
- Increase the simulation rate to 10 (or higher).
- Wait until the level in the tundish is about 70%, to avoid inclusion problems.
- Set the simulation rate to 1 and start teeming from the tundish to the mold with 2450 kg min^{-1} .
- Wait until the mold level is about 80%.
- Choose a casting speed of 1.2 m min^{-1} .
- When the tundish level reaches about 80%, set the ladle flow to match the flow from the tundish, i.e. 4900 kg min^{-1} .
- Increase the simulation rate to 16 and wait until the current ladle is emptied.
- Set simulation rate to 2 and rotate the ladle turret to bring the new ladle over the tundish.
- Set the ladle flow rate to maximum until the tundish level reached 80%.
- Set ladle flow back to 4900 kg min^{-1} .
- Set simulation rate to 16.
- Wait until the current ladle is emptied.
- Set simulation rate to 2.
- Rotate ladle turret.
- Fill the tundish to over 80% again with maximum flow
- Set ladle flow back to 4900 kg min^{-1} .
- Set simulation rate to 16.
- Watch the strand run-out.

